



C O M M E R C I A L

**EXTERNALLY BEADED
ALUMINIUM
CASEMENT WINDOW**

Externally beaded aluminium casement window extruded from aluminium which is suitable for a wide range of glazing applications. Available in a wide range of colours which will enhance the aesthetic appearance of all commercial and industrial buildings, new build or refurbishment.



Externally Beaded Aluminium Casement Window

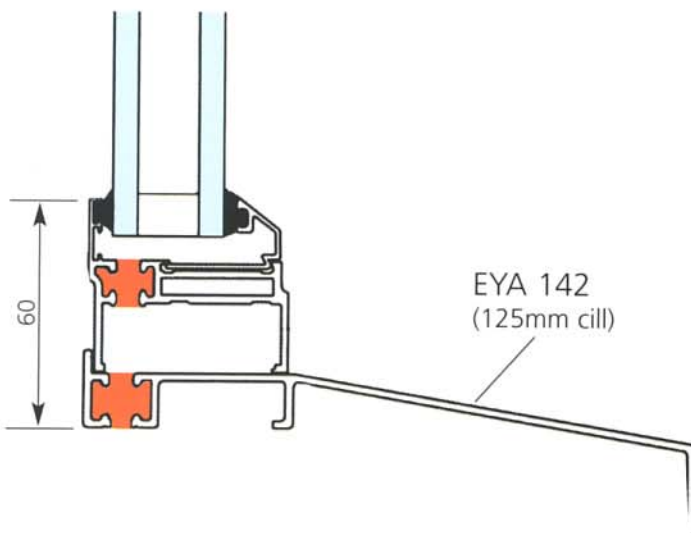
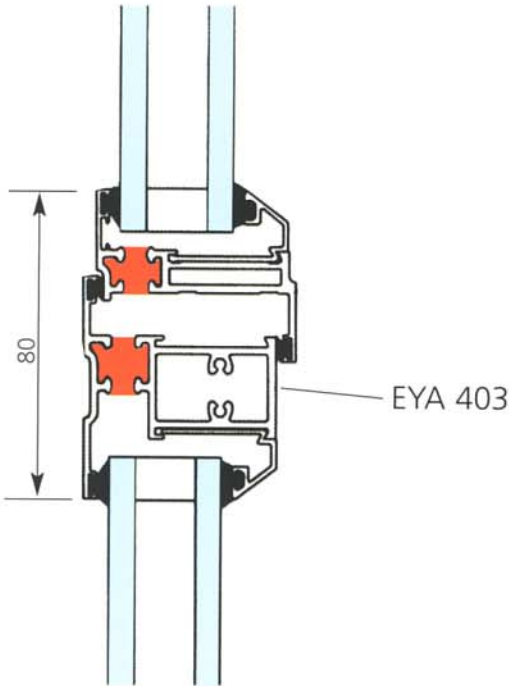
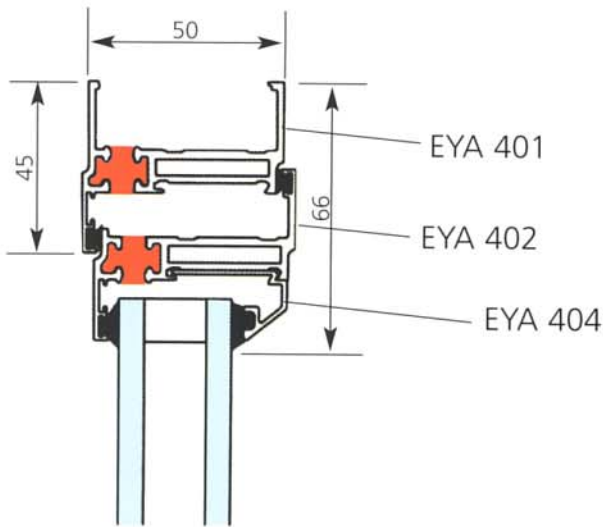

Specification

Thermally broken using Polyurethane resin barrier.
 Stainless steel friction stays.
 Cockspur locking handles.
 28mm sealed unit approved to BS 5713.
 Mechanically jointed using crimped corner joints manufactured in aluminium.
 Available in white as standard.
 EPDM dry glazing system.
 Double weather sealed.
 All ironmongery is a standard anodised finish to BS 1615 (handles and trickle vents).

Performance

Manufactured and installed within an ISO 9002 approved quality management system.
 Weather tested to BS 5368 (Part 1, 2 & 3) and BS 6375.
 Anodised to BS 1615 (1972).
 Paint finish BS 6496 (1984) by Interpon D 525 approved specialist.
 Extruded from AM 62 Alloy - ISO EN 6063.
 Mechanical properties guaranteed to BS 1474: 1987 6063-T6.

