

LUMA FLAT ROOFLIGHT INSTALLATION GUIDE

Issue 1



CONTENTS

Exploded View	3
Parts Lists - Double-Glazed System	4
Parts Lists - Triple-Glazed System	5
Specifications	6
Pre Installation Checks	9
Size Specification	10
Tools and Equipment	11
Installation	12
Pre installation	12
Kerb Preparation	12
Apply silicone seal to kerb	14
Position rooflight	15
Secure rooflight	16
Internal finishings	18

If in doubt at any stage

Please contact our Technical Support
for additional support or advice.



01773 842100



technicalroofing@eurocell.co.uk

For purchasing products please telephone
01773 842222 and ask for Eurocell Sales Department.



STATEMENT

All the information contained in this manual is provided for guidance only and is given in good faith, but without warranty or guarantee of any kind, whether implied or expressed. It must be understood that Eurocell has no control over how the information in this document is interpreted and therefore cannot be held responsible for any resulting fabrication or product failure, howsoever caused.

Statutory regulations regarding health and safety of operatives / personnel should be strictly adhered to. Eurocell cannot be held responsible for any failure to comply with them. This statement does not affect your, statutory rights.

Eurocell's policy is to continually improve products; therefore methods, materials and changes of specification may be made from time to time without prior notice.

UPDATING OF PRODUCT MANUAL

To ensure that the product manual is kept up to date, all registered holders of the said manual will be supplied with current amendments immediately upon their release.

It is the responsibility of the appointed holder of the manual to ensure that the information supplied is correctly inserted into the manual and acceptance returned.

For any further information or confirmation regarding the current issue of the Eurocell technical publication, please contact Eurocell Technical department - Technicalroofing@eurocell.co.uk.

EXPLODED VIEW

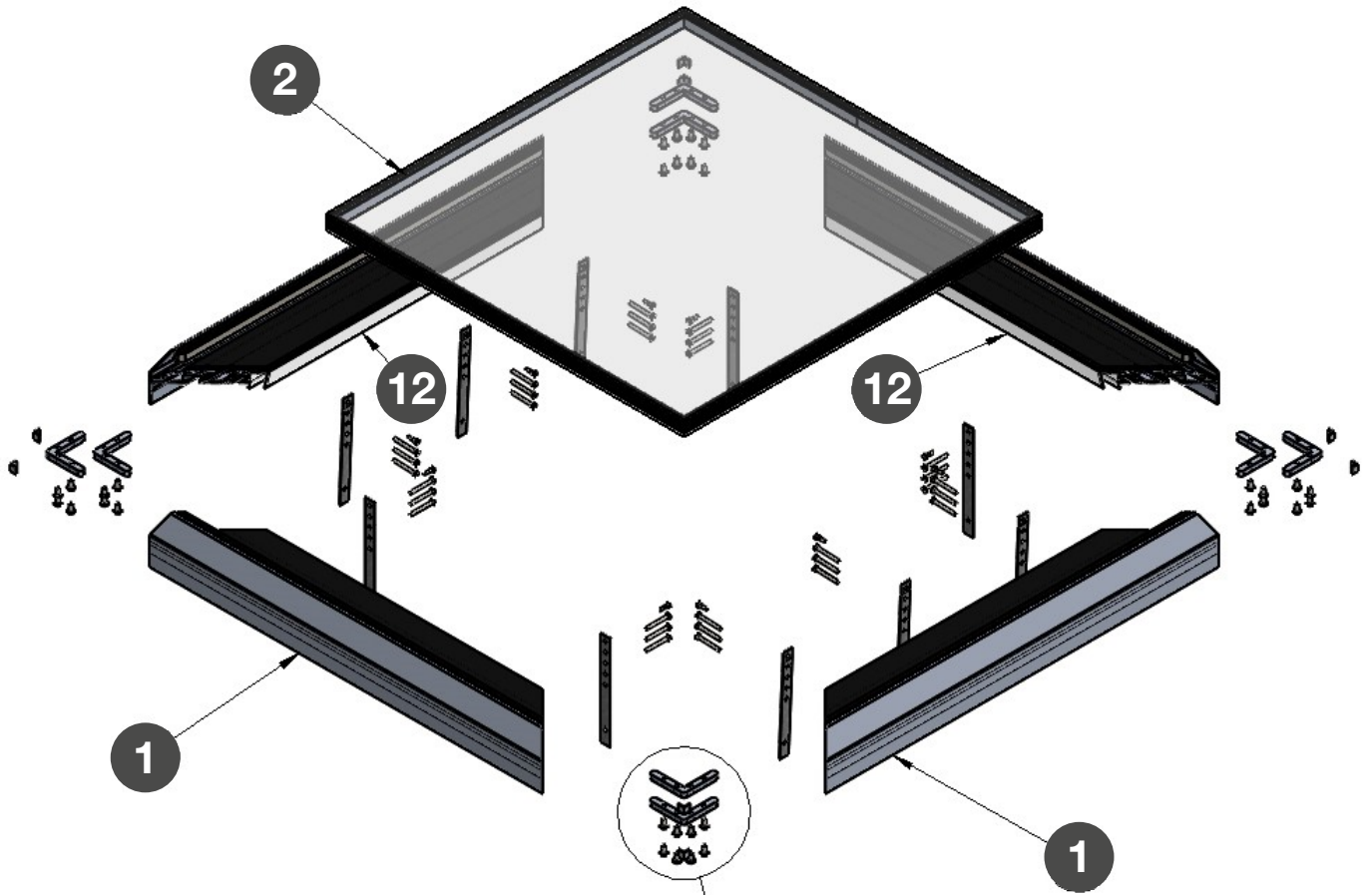

DETAIL VIEW

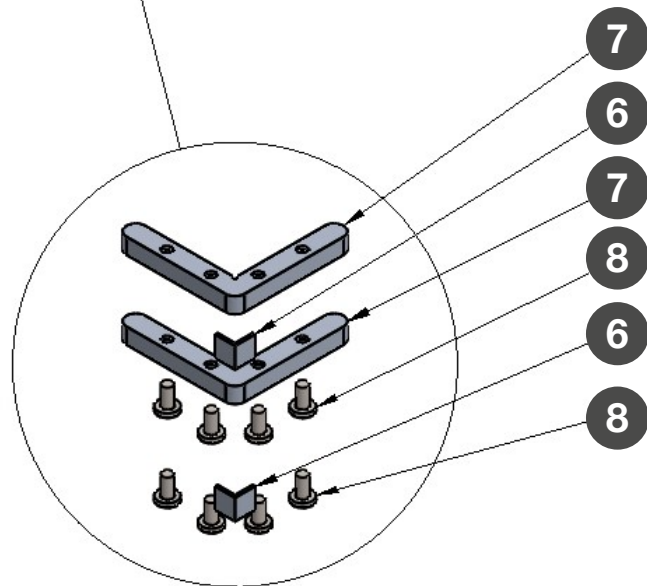

CROSS SECTION - DOUBLE-GLAZED

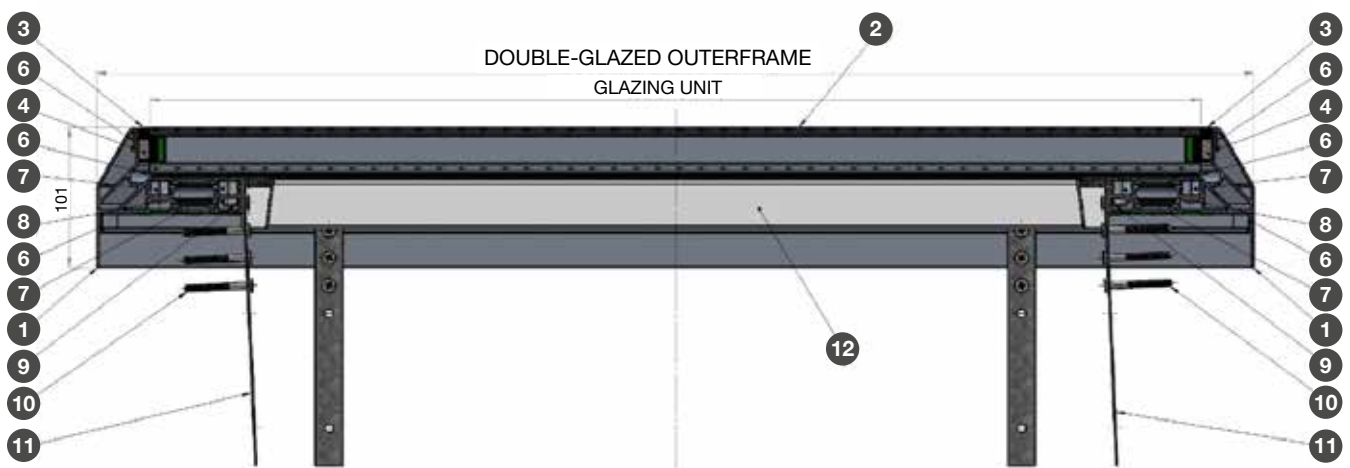

PARTS LIST

ITEM	PART No.	DESCRIPTION
1	FRL5501ABKM	FRL OUTER FRAME - DOUBLE-GLAZED - MATT BLACK
1	FRL5501AW	FRL OUTER FRAME - DOUBLE-GLAZED - WHITE
2	N/A	TRIPLE-GLAZED IGU
3	FRL5403BK	FORMOA 066 WEATHER SEAL
4	FRL5401GY	BACKING ROD - Ø10MM
5	FRL5402BK	STRUCTURAL GLAZING TAPE
6	FRL5504A	ANGLE CLEAT
7	FRL5503A	CORNER BRACKET
8	FRL5602	PAN HEAD SETSCREW M6 x 12MM
9	FRL5603	SELF DRILLING SCREW 4.8 x 16MM
10	FRL5604	WOODSCREW 5.0 x 50MM
11	FRL5601S	FIXING PLATE
12	ET12564	INTERNAL TRIM

CROSS SECTION - TRIPLE-GLAZED

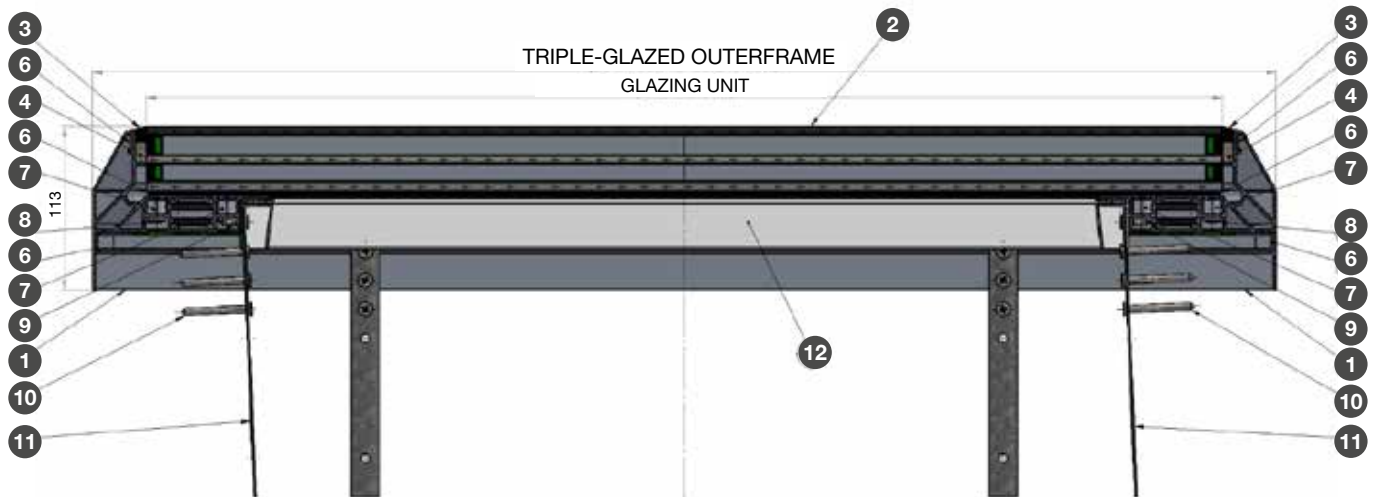

PARTS LIST

ITEM	PART No.	DESCRIPTION
1	FRL5502ABKM	FRL OUTER FRAME - TRIPLE-GLAZED - MATT BLACK
1	FRL5502AW	FRL OUTER FRAME - TRIPLE-GLAZED - WHITE
2	N/A	TRIPLE-GLAZED IGU
3	FRL5403BK	FORMOA 066 WEATHER SEAL
4	FRL5401GY	BACKING ROD – Ø10MM
5	FRL5402BK	STRUCTURAL GLAZING TAPE
6	FRL5504A	ANGLE CLEAT
7	FRL5503A	CORNER BRACKET
8	FRL5602	PAN HEAD SETSCREW M6 x 12MM
9	FRL5603	SELF DRILLING SCREW 4.8 x 16MM
10	FRL5604	WOODSCREW 5.0 x 50MM
11	FRL5601S	FIXING PLATE
12	ET12564	INTERNAL TRIM

SPECIFICATION

FRAME SPECIFICATION

- ▶ Thermally broken T5-6063 aluminium frame sections combine strength with lightweight construction.
- ▶ Frame design includes internal drainage feature in case external weatherseal becomes compromised.
- ▶ Marine grade powder coated surface finish to withstand harshest weather conditions. All powder coating to QUALICOAT standards and specifications which generally exceeds the BS EN 12206 specification for powder coating.

Standard Colours:

Black	RAL 9005 CM
White	RAL 9003

(Special colours available on request, special colours are sprayed onto White profile)

PITCH RANGE

This document and information contained herein is based upon an installation pitch of 2.5°.

PLEASE NOTE: Luma units can be installed up to a maximum pitch of 10°. Please seek technical advice to confirm order sizes on any Luma units to be installed at a pitch angle greater than 2.5°.

GLASS UNIT SPECIFICATION

Luma glazing units consist of toughened and laminated glazing panes allowing installation above 5 metres above floor level and swimming pools / hot tubs.

Manufacturing standards for Glazed Units

- ▶ Toughened to BS EN 12150
- ▶ Manufactured to BS EN 1279 Part 2 & 3

Easy Clean glass on all products as standard – keeps glass cleaner longer and minimises cleaning effort.

DOUBLE-GLAZED OPTION 32.8MM – 30KG/M²

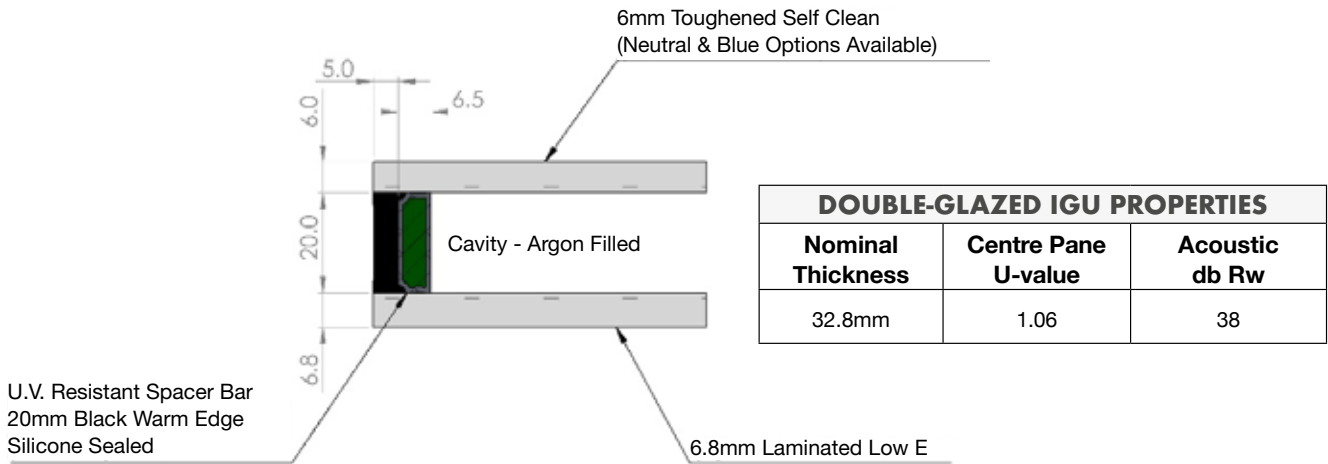

TRIPLE-GLAZED OPTION 44.8MM – 45KG/M²

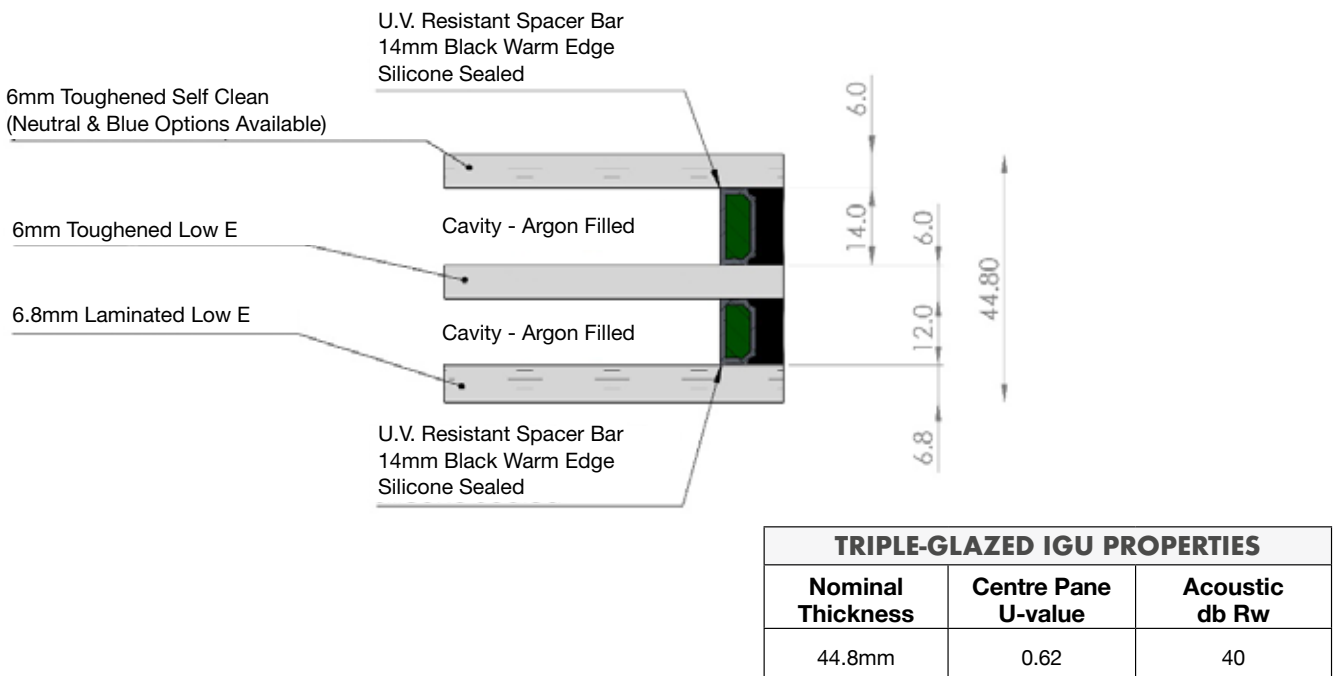

LUMA THERMAL PERFORMANCE

The simulation results below were performed using Win Iso @ version 2.7.6, strictly in accordance with the requirements of BS EN ISO 10077-2:2017, using the radiosity approach to frame cavity modeling. The overall Luma U-value was determined strictly in accordance with the requirements of BS EN ISO 10077-1:2017. Results based on an overall external frame size of 1230x1480mm.

Glazing	Thermal Transmittance (Uw) (Based on Internal Developed Area)	Solar Gain (gw)	Visible Light Transmittance
Double -Glazed Sunshade Blue	1.3	0.14	0.17
Double-Glazed Sunshade Neutral	1.3	0.25	0.34
Triple-Glazed Sunshade Blue	0.92	0.11	0.14
Triple-Glazed Sunshade Neutral	0.92	0.20	0.27

PRE INSTALLATION INFORMATION

Ensure a qualified surveyor has verified that all supporting frameworks, walls, and foundations are fit for purpose and this installation satisfies and complies with any Regulatory requirements.

- ▶ **Ensure full site survey is undertaken employing where necessary full risk assessments, method statements and utilising suitable and appropriate lifting equipment and PPE to ensure safe installation.**
- ▶ **Be safe when working at height. Ensure compliance with latest Work At Height Regulations. For more details, visit www.hse.gov.uk/work-at-height. Read ALL the relevant sections completely BEFORE commencing any work, more than one reading may be necessary. Understanding these instructions and having familiarity with the procedures contained within will make the build process a much easier and enjoyable project to undertake.**
- ▶ **Exercise care and caution when opening package.**
- ▶ **Ensure Luma Rooflight Kit is checked against the order acknowledgement provided by Eurocell.**
- ▶ **Before discarding any packaging, check all components are accounted for.**
- ▶ **Dispose of all packaging responsibly, recycling where appropriate.**
- ▶ **Prior to commencing any installation work, the size, type and condition of all Luma Rooflight Kits should be checked against the survey sizes.**

SIZE SPECIFICATION

Manufactured to “Internal Dimensions” or “Structural Opening” size.

Please ensure all survey dimensions correspond to internal opening size only.

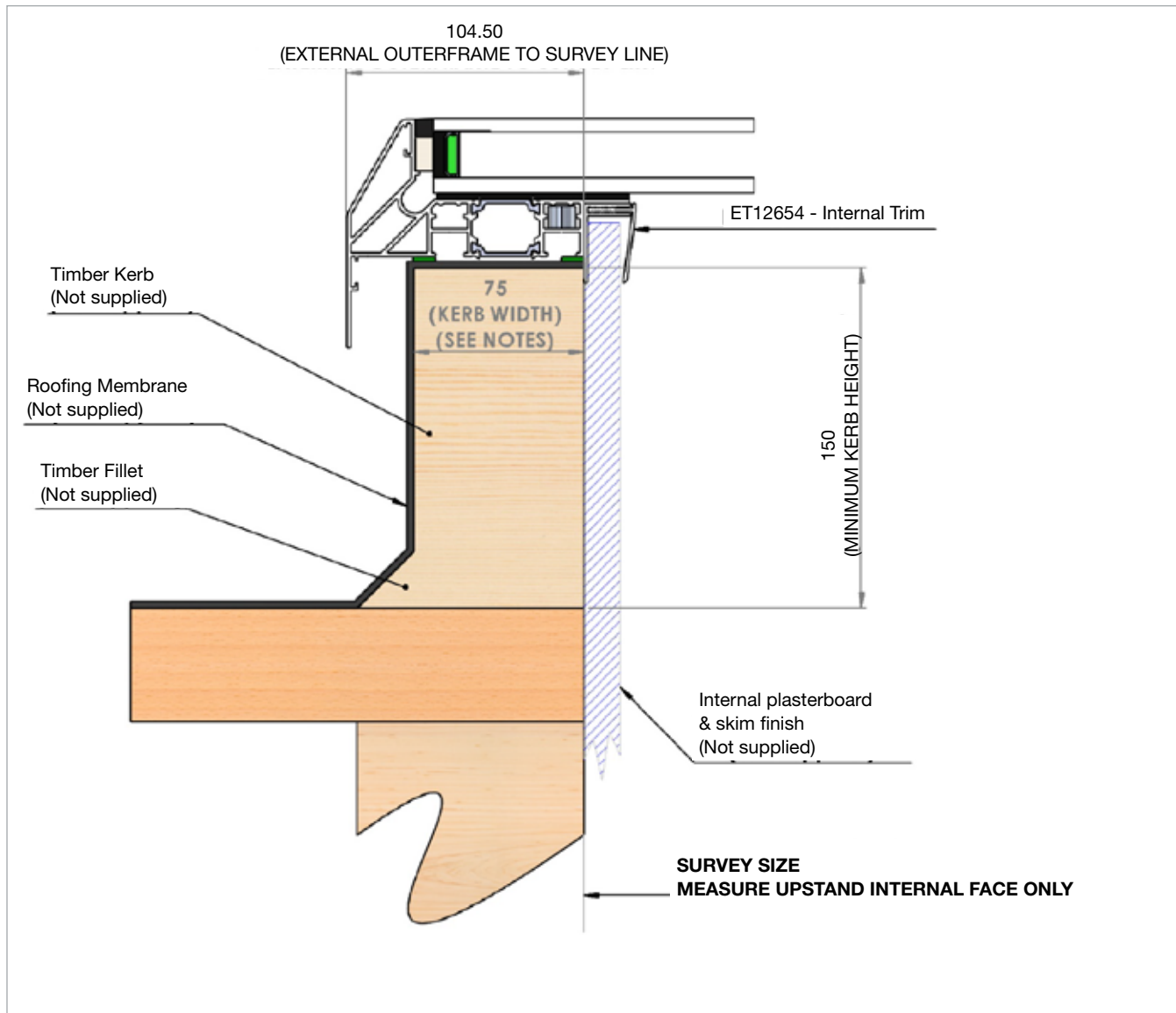

PLEASE NOTE: Maximum kerb width including roofing weatherproof membrane should not exceed 80mm to ensure system drainage is not compromised.

TOOLS & EQUIPMENT

Items not supplied.

PART No.	DESCRIPTION	
N/A	Power Driver	
FIXALLCRYSTAL	Adhesive Sealant	
SGPOWER	Caulking Gun	
STA033719	Tape Measure	
STA143072	Level	
STA210122	Retractable Knife	

INSTALLATION

PRE INSTALLATION

1.0

Ensure full site survey is undertaken employing where necessary full risk assessments, method statements and utilising suitable and appropriate lifting equipment to ensure safe installation.

KERB PREPARATION

2.0

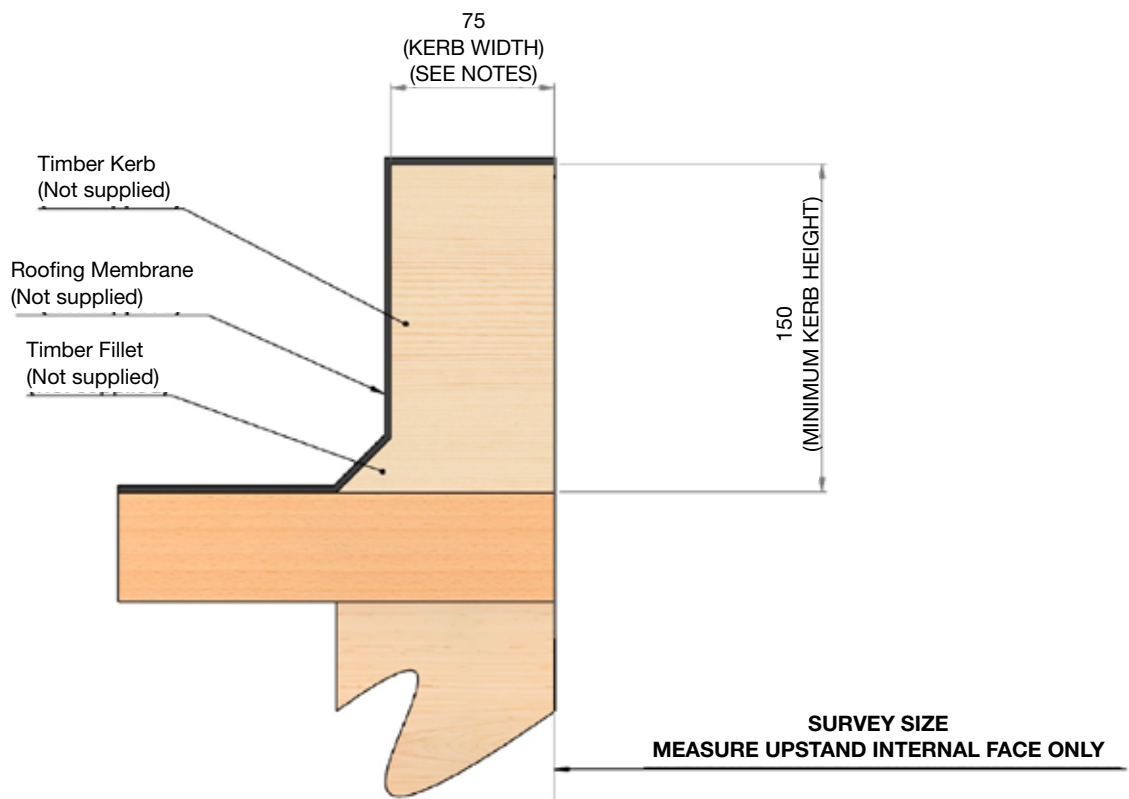

Prepare a 75mm width timber kerb for the rooflight (not supplied with rooflight).

Please note: - Maximum kerb width including roofing weatherproof membrane should not exceed 80mm to ensure system drainage is not compromised.

To ensure compliance with Building Regulations, the kerb should be a minimum of 150mm in height (can be increased if required) from the finished roof level. It is important to note that the internal dimensions of your kerb should match the internal dimensions of the rooflight/size ordered.

2.1

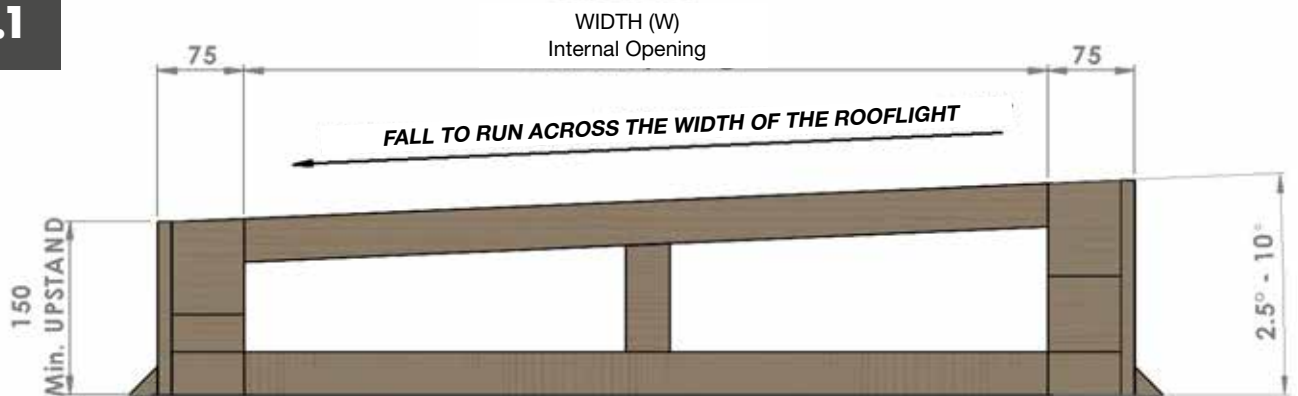

The rooflight needs to be pitched at a minimum of 2.5° to allow disbursement of water. If the roof does not allow for this minimum pitch, accommodate the minimum pitch in the construction of the timber kerb. It is recommended that the fall run across the 'width' or 'shorter side' of the rooflight minimising kerb height and maximising overall aesthetic appearance.

Ensure the kerb is fully 'weathered in' or 'flushed' utilising an approved weatherproof membrane or flashing kit.

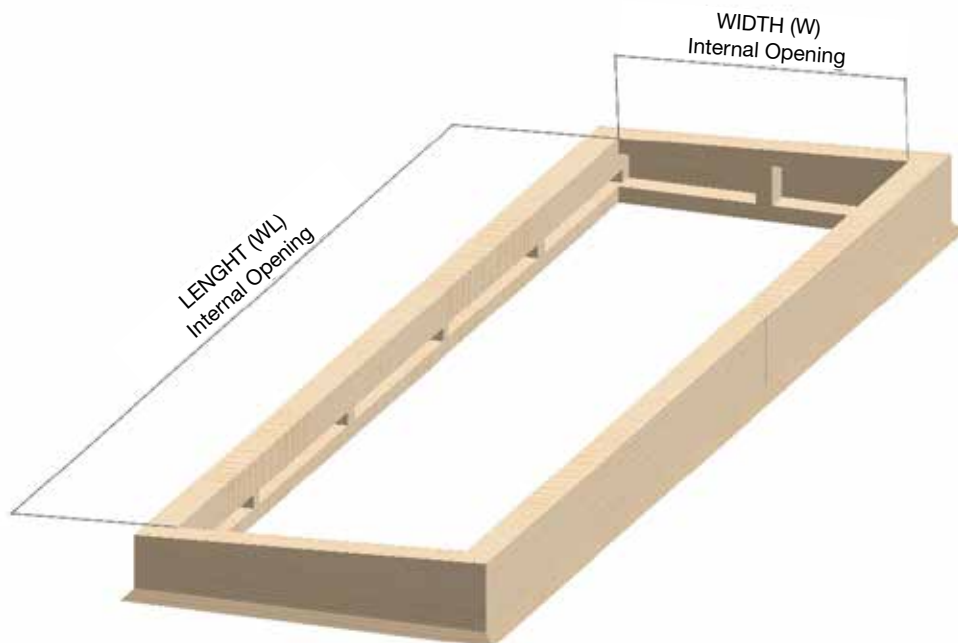

APPLY ADHESIVE SEAL TO KERB

3.0

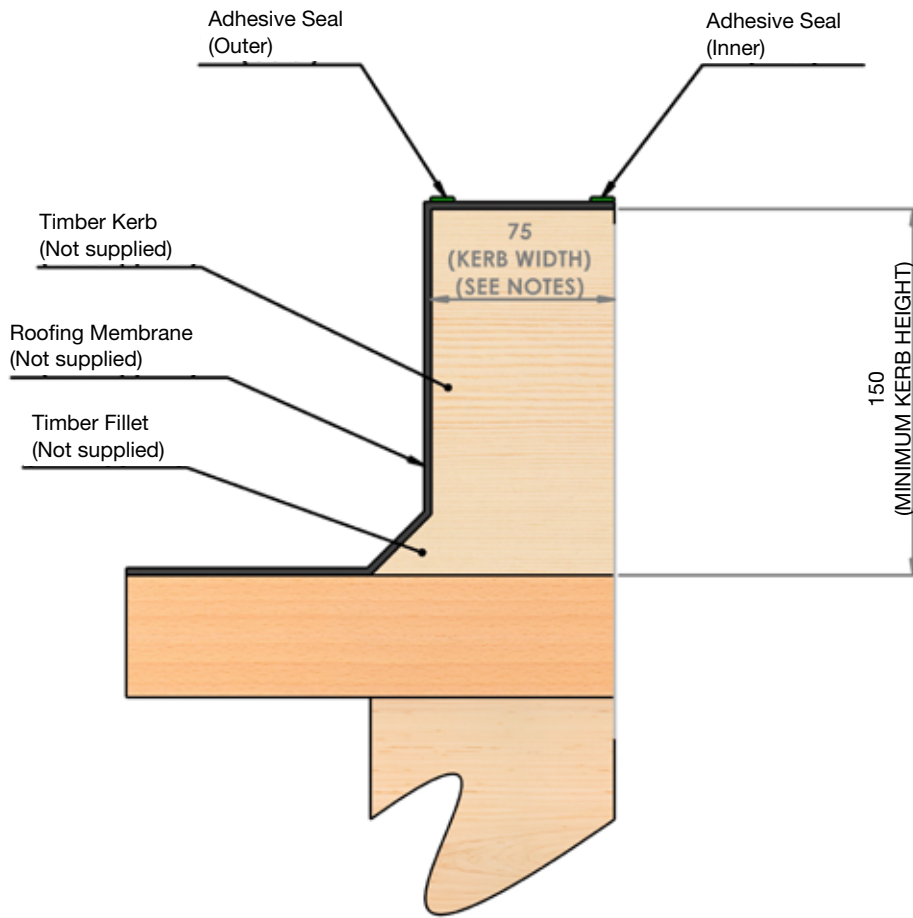

Before lifting the rooflight into position apply adhesive seals to the kerb. Apply two (2) generous beads of adhesive seal around and to the top surface of the kerb. Apply one bead to the internal and external perimeters of the kerb.

Eurocell recommends "Fix All High Tack" adhesive sealant (Part No. FIXALLCRYSTAL) - a high quality, neutral, elastic, 1-component adhesive sealant based on SMX-Polymer with a very high initial tack.

POSITION ROOFLIGHT

4.0

Please note: - Before attempting to lift the Luma rooflight into position, ensure the base and drainage section has been clearly identified by locating label on external surface of outer frame.

Ensure the drainage/base section is to be installed to the bottom/base of the pitch to facilitate inbuilt drainage feature.

**Luma
Base/Drainage Section**

4.1

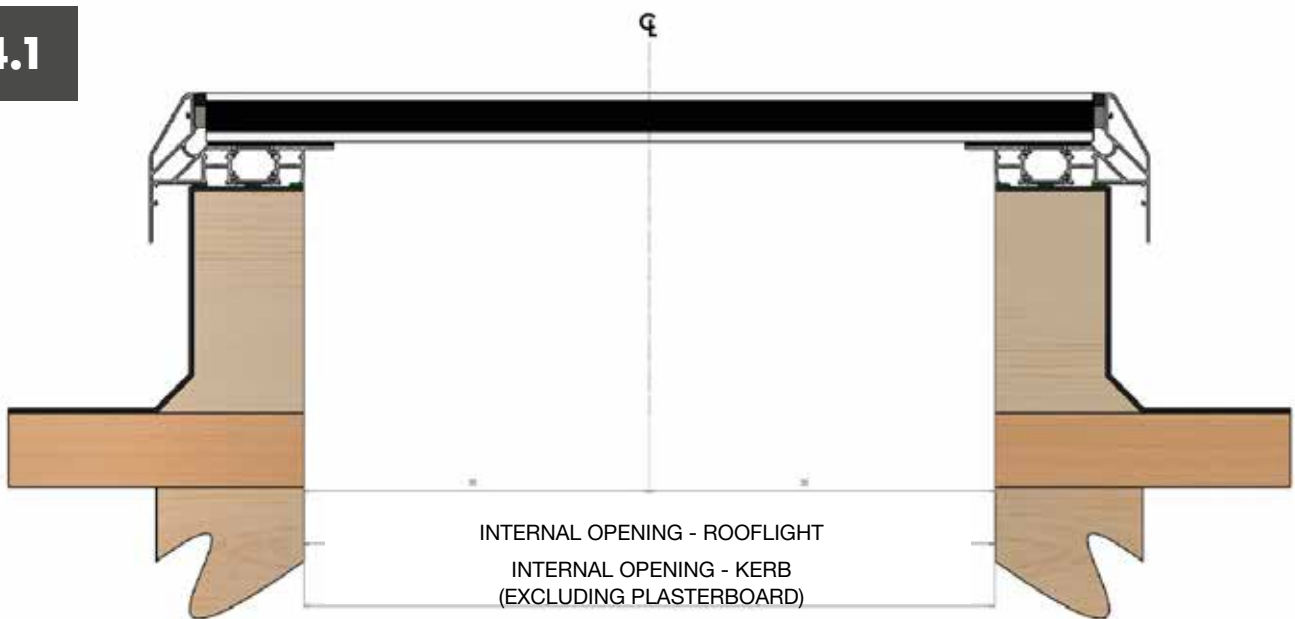

Observing necessary risk assessments, method statements, Health & Safety requirements and safely utilising all appropriate lifting equipment and PPE, carefully bring the rooflight into position aligning the rooflight centrally over the kerb internal opening.

SECURE ROOFLIGHT

5.0

Once in position, the rooflight is secured in position from inside the internal opening using the following components.



Item 9



Item 10



Item 11

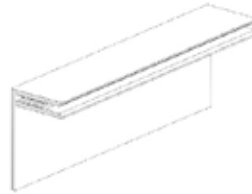

Item 12

ITEM	PART No.	DESCRIPTION
9	FRL5603	SELF DRILLING SCREW 4.8 x 16MM
10	FRL5604	WOODSCREW 5.0 x 50MM
11	FRL5601S	FIXING PLATE
12	ET12564	INTERNAL TRIM

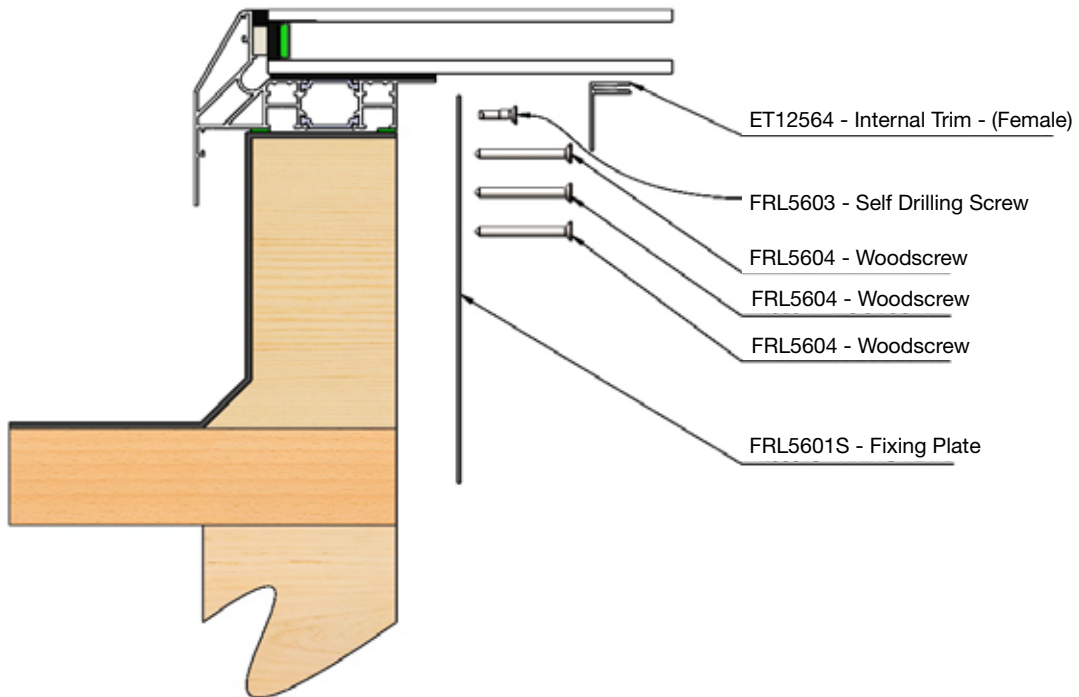

5.1



Locate top hole of FRL5601S-Fixing Plate to "V" groove on outer frame internal face and secure in place using FRL5603 4.8x16mm Self Drilling Screw 150mm away from each corner.

Secure Luma rooflight frame to kerb using FRL5601S-Fixing Plate and three (3) FRL5604-5x50mm Woodscrew.

Additional fixing plates should be positioned equally spaced along each internal opening face at centres **NOT** to exceed 500mm.

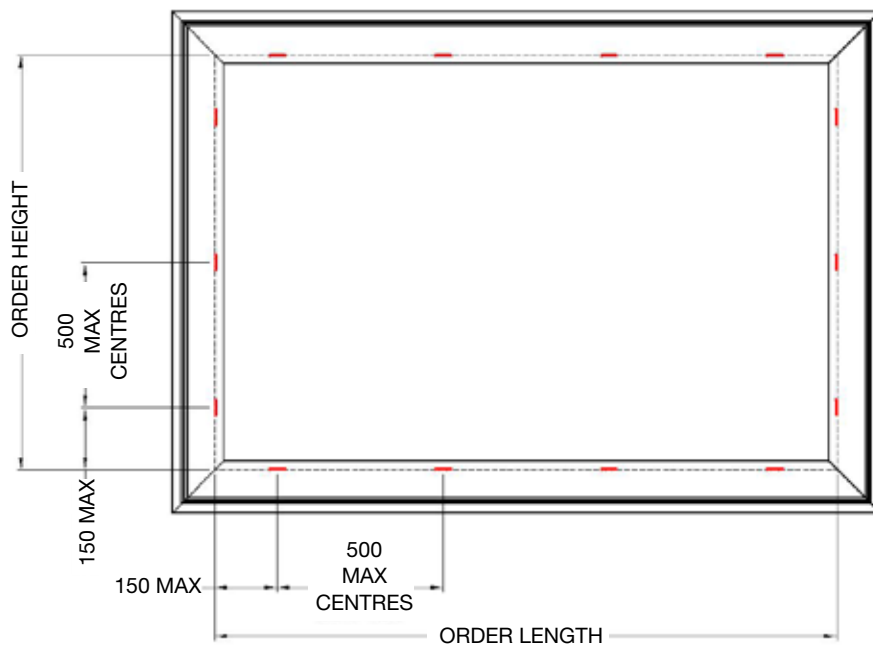

5.2

Install item 12 - ET12564 – Female Section to internal opening of Luma frame utilising Fix All High Tack adhesive sealant.

INTERNAL FINISHING

6.0

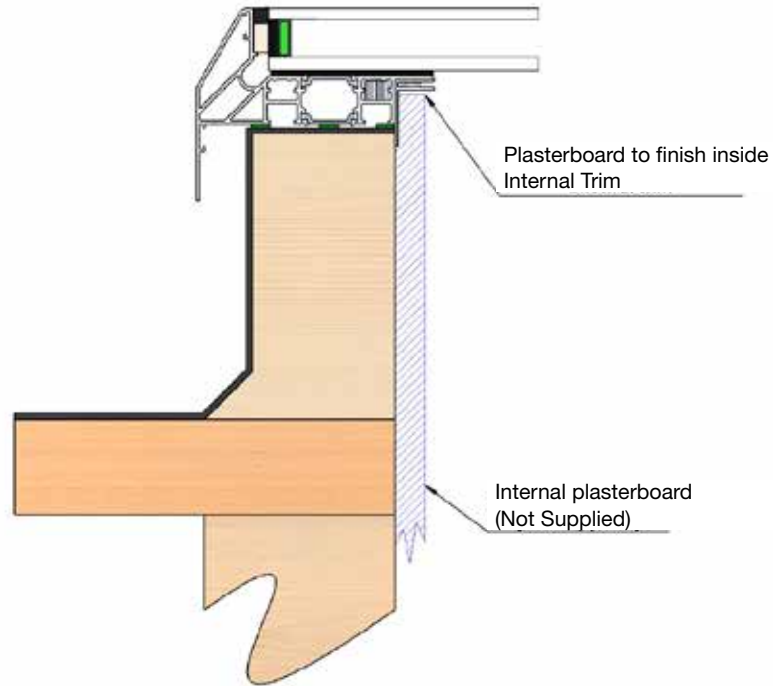

After securing the rooflight in position, proceed to install and fix all internal plasterboards ensuring plasterboards finish inside ET12564-Internal Trim.

6.1

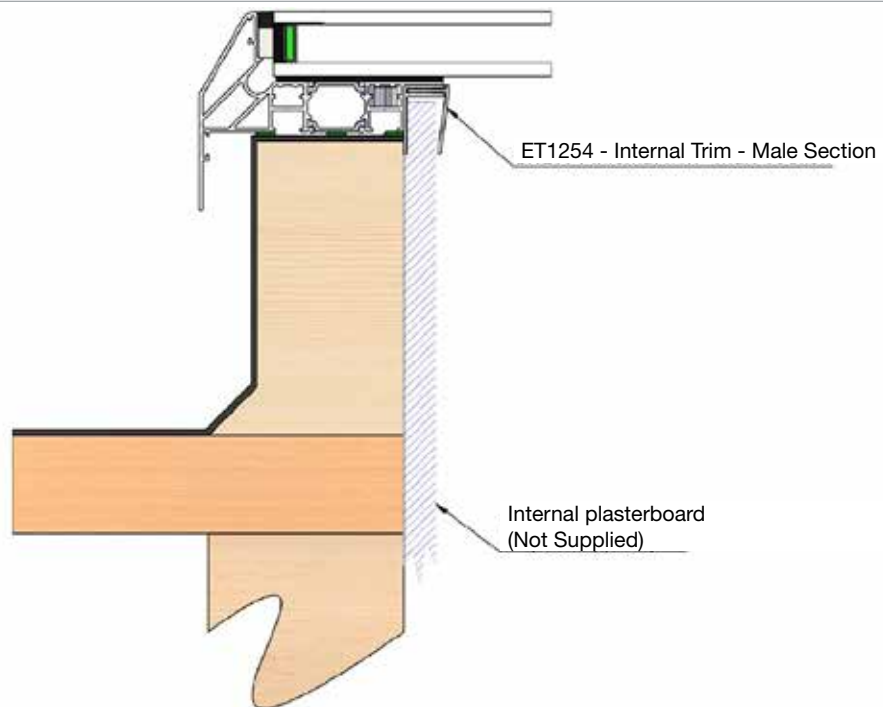

Apply surface finishes to all internal plasterboards and finally install male section of ET12564 to enclose plasterboard.

CONTACT

For further information, contact the Eurocell Technical Team on **01773 842100**. Visit **eurocell.co.uk** to find installation guides and videos for Eurocell products.

EYG commercial & trade
glazing solutions

